



ARMED GUARD ELECTRONIC SECURITY

Your Source for 12-Volt Alarm Systems

When a theft attempt is detected, the system disables the starter circuit, sounds the audible alarm, and flashes the motorcycle's lights. If power to the alarm is cut, the starter circuit remains disabled, creating a high degree of security. We have been manufacturing motorcycle alarms in the United States since 1993.

At the heart of the security system is the sophisticated Armed Guard™ G-Force™ digital sensing element. When the remote controlled alarm is placed in "guard" mode, the sensor actually forms an electronic lock to earth's gravitational pull. Once armed, any movement of the bike, even one inch, will trigger the system, **sounding the siren, flashing the lights, and disabling the starter**. The G-Force™ digital sensing element also makes the security system *highly* resistant to false alarms caused by loud motorcycle pipes, a concern for many motorcyclists. The rider can adjust the sensitivity level of the G-Force element using the remote transmitter.

The Armed Guard G-Force™ list of features include:

- Proprietary plug fit harnesses – No wires to cut on your motorcycle! Quick Installation.
- Starter disable relay with fail-safe latching function
- Waterproof electronics that are ruggedized and epoxy potted and are covered by a 2 year replacement warranty
- Toll Free 800 Number for Warranty Service and Technical Support
- Detailed Motorcycle Model Specific Installation and Operating Manuals included with each alarm
- Compact modular design to ease installation and to fit on most bikes
- User adjustable G-Force™ digital motion sensing element
- Flashing turn signal outputs
- Voltage/Ignition monitor circuitry
- Siren Options, including Durable Stainless Steel, Battery Backup, High Output
- Remote transmitter panic feature
- Alarm chirping feature on arm and disarm
- Warning LED
- Available with adjustable electronic perimeter sensor with selectable on/off function,
- Available with 4 watt long range paging, with selectable vibration & audible alerts

Armed Guard Electronic Security has been designing and manufacturing motorcycle alarm systems since 1993. Our G-Force alarm is manufactured in the United States and is designed by a motorcycle rider. We stand behind our alarm systems with unparalleled customer support.

Armed Guard Electronic Security

746 Mooney Street * Independence, OR 97351
503-606-2959 FAX 971-231-2465 alarms@armedguard.com

Detailed Installation and Operation Manual

Your Armed Guard G-Force Alarm System includes a detailed installation and operations manual with pictures and a wiring diagram. Our manuals are also available on our website www.armedguard.com.

Sample wiring diagram and pictures for the installation process (your custom wiring harness will include a manual specific to your bike)

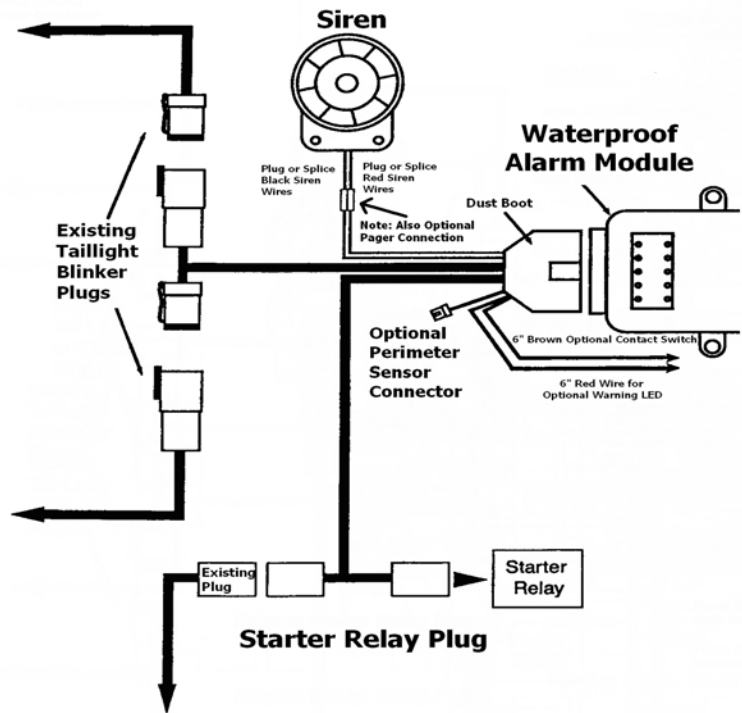

Sample picture in an installation manual. This sample picture is for a Suzuki Flashing Lights Plug Fit Connection. Your custom wiring harness will include OEM connectors specific to your bike. We buy our connectors from the same source as your bike builder.

